

AEROPAC Assembly & operating instructions

The low-noise AEROPAC provides controlled and energy-saving ventilation indoors

Function

The low-noise AEROPAC wall-mounted ventilator uses an electrically operated blower to draw in fresh air from the outside and provide controlled and energy efficient fresh filtered air inside.

When the blower is switched off, the unit equalises the pressure of the indoor and outdoor air to allow fresh air from the outside to flow inside (pressure differential principle).

Various filters may be used, depending on the intended use of the unit:

Features

AEROPAC G3 dust filter	For coarse dust
AEROPAC F5 dust filter	For pollen/fine dust
AEROPAC activated carbon filter	E.g. exhaust fume odours

The AEROPAC offers the following features:

- Sound absorption
- Low internal noise
- Filters dust and exhaust fume odours
- Filter change indicator
- Adjustable airflow
- Timer function

Scope of delivery

- AEROPAC wall-mounted ventilator with G3 dust filter
- Installation and operating instructions plus drilling template
- Mounting kit consisting of two dowels and two screws
- Weather grille F. (made of plastic)
- PVC ventilation pipe, Ø 80 mm, 500 mm long

Safety information

- The unit should not be operated by people (including children) with physical, sensory or mental disabilities, nor by people with insufficient experience or previous knowledge, unless adequate supervision is provided or detailed instructions on how to use the unit are issued by a responsible person.
- Do not allow children to play with the unit.

To avoid injury and material damage it is mandatory to observe the following instructions:

- Only insert the plug of the standard connecting cable into a suitable 230 V AC socket.
- If the mains connection cable for this device is damaged, it must be replaced by Acoustica, their customer service department, or similar qualified personnel in order to prevent hazards.
- Should work on the 230 V AC mains power supply be necessary in order to connect the device, it may only be performed by a qualified electrician.
- An all-pole safety isolation is required when the customer lays the power cable. The fuses may need to be removed.
- Relevant country-specific regulations must be strictly followed for all work on the voltage supply system or house wiring system.
- Should a hard object or fluid get into the interior of the device, stop operation immediately and disconnect the device from the mains power supply.

Grd Flr 6A Nelson St
Annandale NSW 2038
Australia

Ph: 1300 722 825
+61 2 9550 2900

Fax: +61 2 9550 5665

info@acoustica.com.au

www.acoustica.com.au

Technical Data

Internal noise measured according to DIN EN ISO 3741	At 60 m ³ /h (with A ₀ = 10 m ²): LPA = 24 dB(A)
Sound absorption in accordance with DIN EN ISO 140-10: Two open sliders One open slider All sliders closed	With G3 dust filter: D _{n,e,w} = 50 dB D _{n,e,w} = 53 dB D _{n,e,w} = 57 dB
Air throughput with G3 filter F5 filter activated carbon filter	Approx. 30 – 180 m ³ /h Approx. 15 – 160 m ³ /h Approx. 15 – 160 m ³ /h
Supply voltage	230 V AC/50 Hz, 0.14 amps
Power consumption: at min. blower level at 60 m ³ /h at max. blower level	2 W 5 W 30 W
Protection class	II, all-insulated
Degree of protection	IP 40
Housing material	ASA, dyed
Connecting cable (wound up in cable storage compartment)	Max. 4.5 m long, white, with Euro plug
Dimensions (W x H x D)	270 mm x 467 mm x 132 mm
Weight	3.12 kg
Technical approval	Z–51.5–206

Accessories

Description	Colour	Material number
AEROPAC front panel, similar to RAL 9003	Alpine white*	L5460260-004010
AEROPAC front panel, similar to RAL 9005	Deep black*	L5460260-023010
AEROPAC front panel, similar to RAL 7006	Beige grey*	L5460260-015010
AEROPAC front panel, similar to RAL 7039	Quartz grey*	L5460260-013010
AEROPAC G3 dust filter (for coarse dust)	Black	L5460270-097010
AEROPAC F5 dust filter (for pollen/fine dust)	White	L5460280-096010
AEROPAC activated carbon filter (e.g. for exhaust fume odours)	Black	L5460290-099010
Weather grille F. NW 75, similar to RAL 9010	White	158289
Weather grille F. NW 75, similar to RAL 8019	Brown	158296
PVC pipe, NW 75, outside Ø 80 mm, 500 mm long	Grey	135600

* High-gloss

Installation

Requirements

- Suitable location for installation:
 - In the vicinity of a 230 V AC power connection (max. cable length: 4.5 m)
 - When a permanent mains connection is used: over a flush-mounted box
 - Not in the immediate vicinity of radiator thermostats
- On a smooth, even wall
- Ensure that no cables or pipes are concealed inside the wall at the unit's designated position
- Keep the unit free from dirt during installation and before start-up
- To prevent damage to the high-quality surface of the unit, it is advisable to wear suitable gloves during the installation.

Installation

Step 1: Marking the holes and drilling the core hole

NOTICE Risk of damage to property by drilling through concealed cables or pipes.

Before installing the unit, use a suitable cable and pipe detector at the installation location to identify the presence of concealed cables or pipes in the wall (such as water pipes).

1. Use a water level to level the drilling template (included in the delivery) at a suitable position (see the installation requirements) and attach to the wall.
2. Mark two drilling mounting holes and the core hole bore (for the supply air from outside) on the wall. If required, mark an additional mounting drill hole (B) that may be used to additionally secure the unit.
3. Drill the core hole: ($\varnothing \Rightarrow 90-93$ mm). Using a hammer drill at an angle of approx. 2° to 5° , drill a hole through to the outside wall.

Step 2: Drilling the mounting holes and inserting the fixing screws

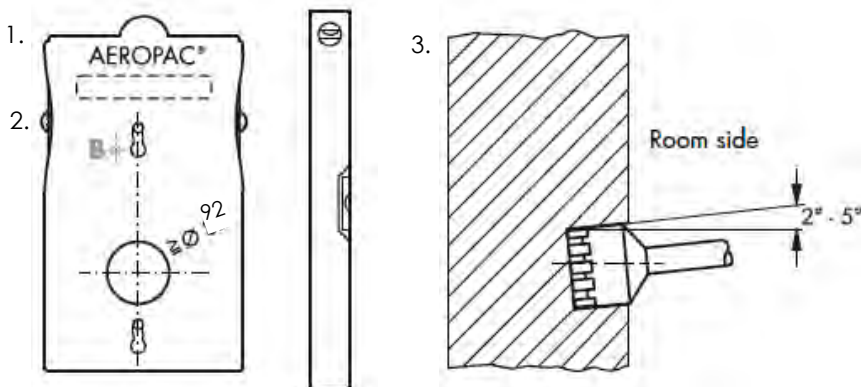

1. Drill the two marked mounting holes and, if required, the additional mounting hole (B) (all drilled holes should have a diameter of 8 mm and be at least 45 mm deep).
2. Insert two S8 dowels (included in the delivery) into the drill holes. If necessary, insert a further dowel into the additional mounting hole (B).
Note: depending on the type of wall (e.g. plasterboard), suitable dowels may need to be provided by the customer for inserting into the drill holes.

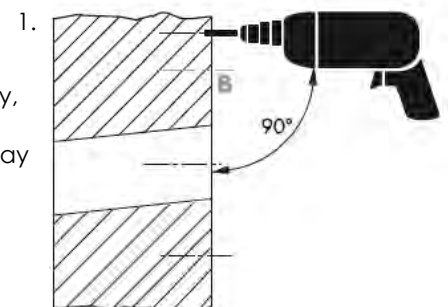

Recommended unit position

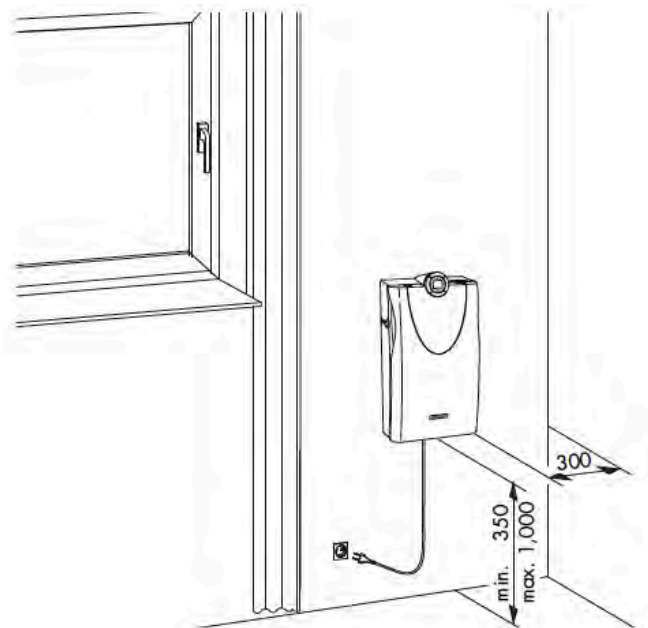

3. Insert the two supplied countersunk wood screws (5 x 50 mm) into the dowels and screw in so that each screw protrudes by 8 mm.

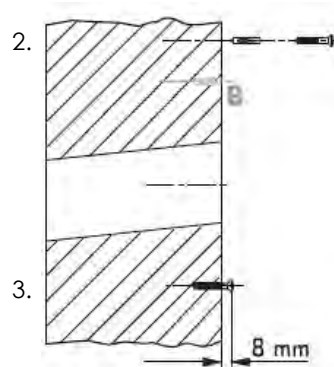

Step 3: Inserting the PVC ventilation pipe into the core boring

1. Shorten the PVC ventilation pipe (included in the delivery) to the thickness of the wall (dimension X).
2. Push the ventilation pipe into the core boring so that both ends are flush with the wall.

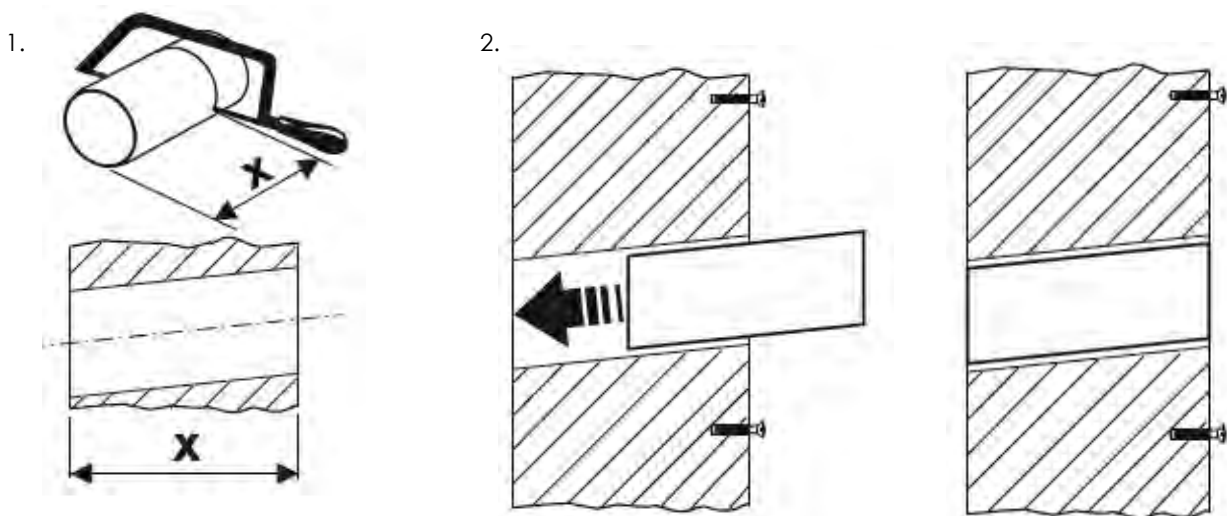

Installation recommendations for the PVC ventilation pipe

The gap between the PVC ventilation pipe and the core boring must be properly sealed inside the room and outside.

Please note the following:

- Ensure that the gap to be sealed is wide enough to allow for movement in the materials.
- Insulate the gap (heat insulation)
- Seal the gap outside so that it is resistant to driving rain
- Seal the gap inside the room so that it is air-tight
- The following principle applies: "inside tighter than outside"

Heat insulation

Clean the gap. Ensure that the holding surfaces are clean and free of grease. In particular, remove any residues of insulating material.

Sealing the PVC ventilation pipe inside the room

To ensure that no warm and humid indoor air enters the outside wall, the gap formed by the intersection of the PVC ventilation pipe and core boring inside the room must be air-tight. We recommend the use of an acrylic sealing compound (observe the manufacturer's instructions).

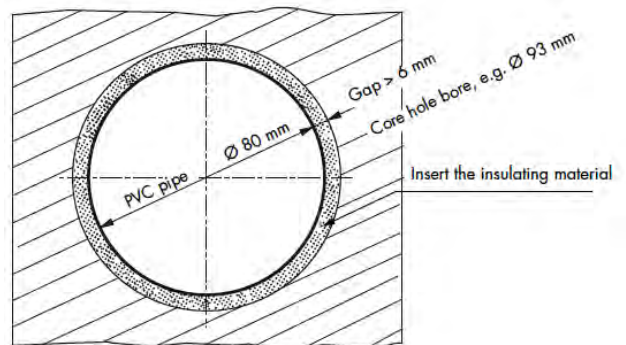

1. Insert a separating layer:
To prevent three-point adhesion from occurring, insert a separating layer, such as a round cord, into the gap.

2. Seal the gap:
Fill the gap around the PVC ventilation pipe with the sealing compound (not included in the delivery).

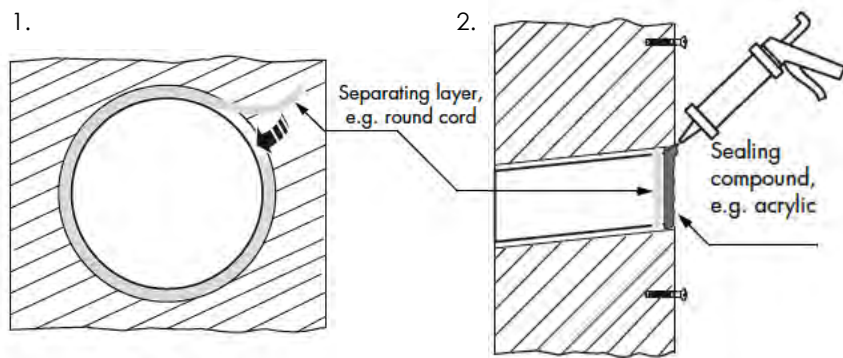

Sealing the PVC ventilation pipe outside

To prevent moisture from entering the outside wall, the exterior gap formed by the intersection of the PVC ventilation pipe and core boring must be filled all round using a durable sealant (resistant to driving rain). We recommend the use of a silicone sealing compound (observe the manufacturer's instructions).

Step 4: Mounting the weather grille

1. Seal the ventilation pipe outside:
To prevent three-point adhesion from occurring, insert a separating layer such as a round cord into the gap.
2. Seal the weather grille:
Apply the sealing compound (not included in the delivery) around the socket piece of the supplied weather grille.
3. Attach the weather grille:
 1. The lamellae must point downwards and should be horizontal.
 2. Push the weather grille's socket piece into the ventilation pipe.
 3. Press the weather grille firmly against the wall so that the silicone is evenly distributed and the ventilation pipe and weather grille are properly sealed.

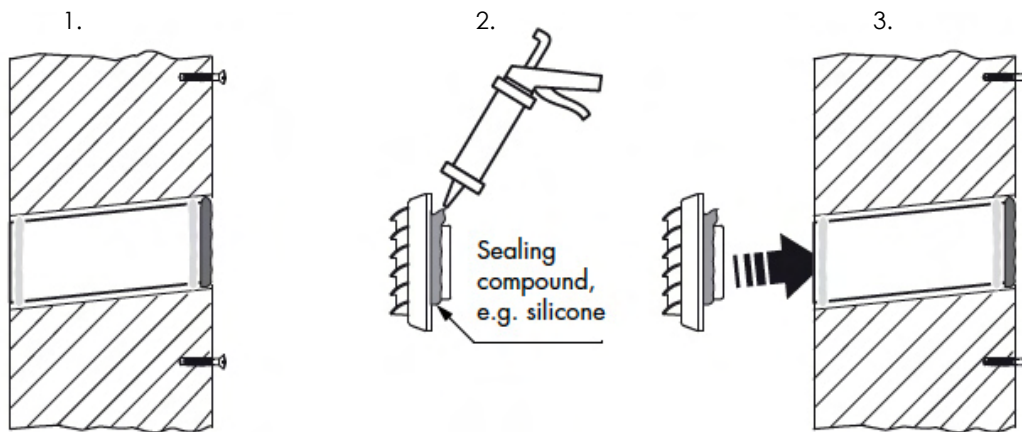

Step 5a: Connecting the mains cable – standard connection

The length of the integrated mains cable is set at the factory to approx. 1.50 m.

The mains cable can be adapted to suit the local conditions (maximum cable length is approx. 4.5 m):

1. Carefully lift the self-adhesive foam film that runs along the cable channel located on the rear of the unit (on the left).
2. Pull as much of the integrated mains cable out of the guiding groove as required. Afterwards, press the mains cable back into the guiding groove.

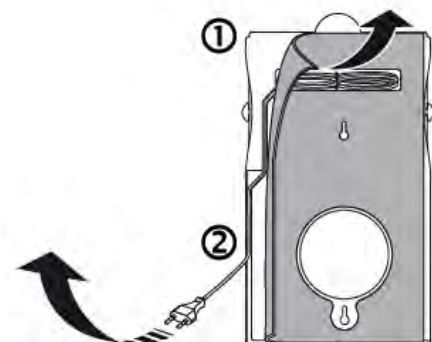

Step 5b: Connecting the mains cable – permanent mains connection

WARNING! Exposed electrical components.

Danger of death by electrocution or fire.

• **MUST be done by licenced electrician** •

Prior to installation, make sure that the power supply is switched off.

1. Shorten the mains cable using a suitable tool such as a wire cutter.
2. Connect the integrated mains cable and cable provided by the customer to one another in a flush-mounted box (e.g. using a lustre terminal).

Note: To ensure the mains cable is connected properly, the unit's cable storage compartment should be positioned over the flush-mounted box.

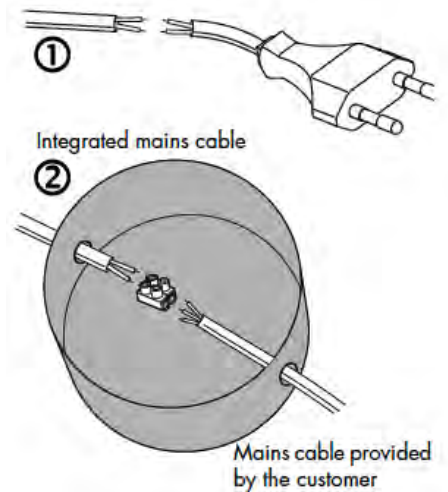

Step 6: Mounting and connecting the AEROPAC

1. Guide the mounting openings on the rear of the unit over the fixing screws and push the unit downwards. Afterwards, check that the unit is secure.
2. Insert the Euro plug of the integrated mains cable into a 230 V AC socket.

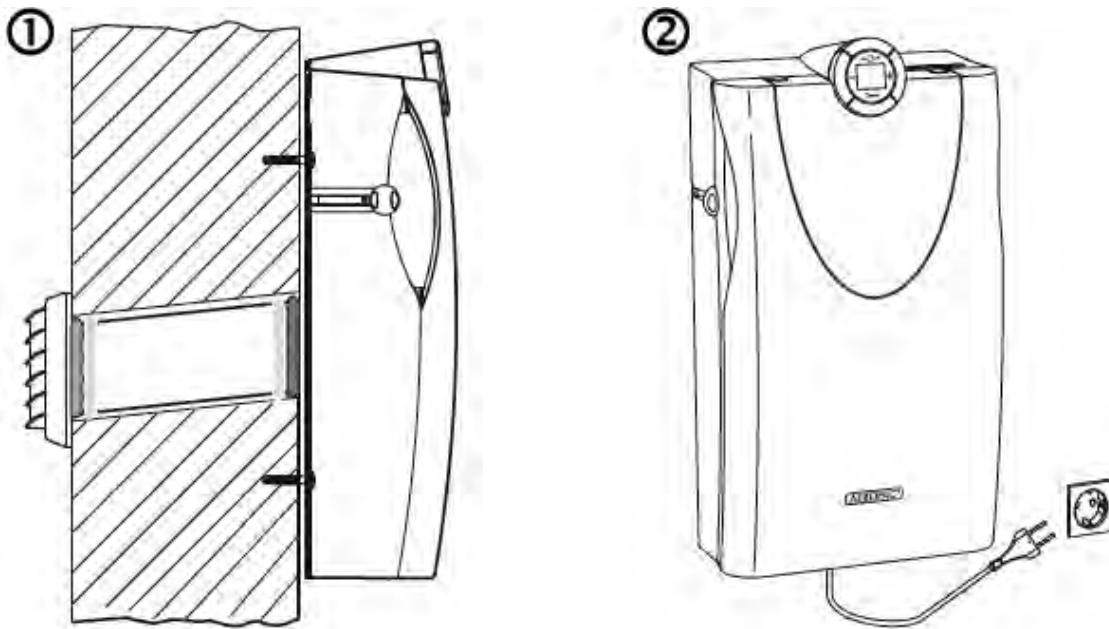

Step 7 (optional): Additional securing of the AEROPAC

An additional screw (not included in the delivery) can be used to secure the AEROPAC, e.g. if the unit is turned by 180° and mounted.

7a. Drill the additional mounting hole *with the aid of the drilling template*:

Detach the unit and perform steps 1 and 2 (pages 8 and 9).

7b. Drill the additional mounting hole *without using the drilling template*:

Check that the unit is secure and perform the following steps (diagrams next page):

1. Depress the two markings on the top of the front panel and pull the panel towards you. Pull out the front panel until you feel some resistance.
2. Grip the bottom of the filter frame's bar and remove the frame from the fixing.
3. Fold back the insulating mat inside.
4. Use a pointed object such as a scriber to pierce the recess (Ø 8 mm) in the unit's rear panel) and mark the additional hole.

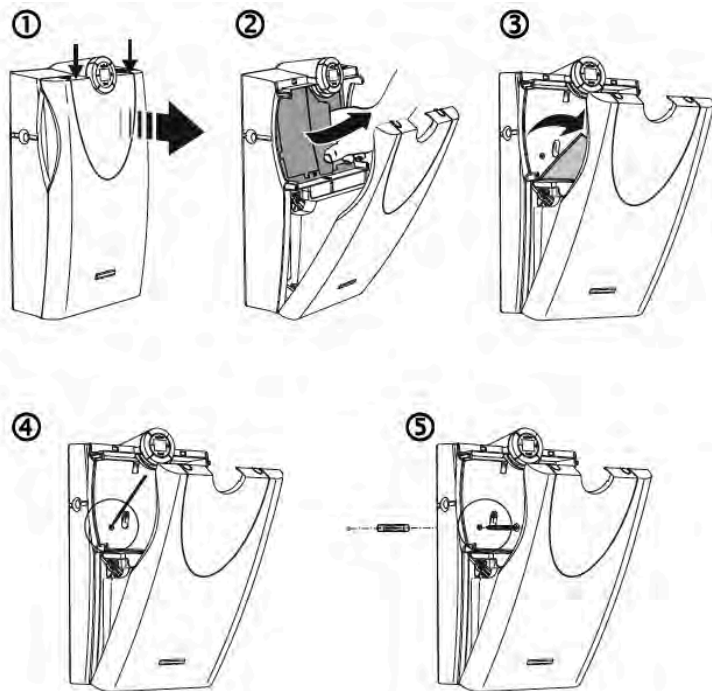

5. Detach the unit, drill the additional hole for securing the unit (\varnothing 8 mm) and insert a suitable dowel (not included in the delivery).
6. Guide the unit over the two fixing screws again and check that the unit is secure. Afterwards, insert a suitable screw through the recess in the unit's rear panel into the dowel and tighten.
7. Now reassemble the unit in reverse order.

Operation

Pressure differential operation

When switched off, the AEROPAC functions as a pressure differential ventilator and equalises the pressure of the indoor and outdoor air. The sliders on the sides of the unit open and close the air outlet so that the airflow is continuously adjustable.

Blower operation

In order for the blower to operate, the unit must be connected to the 230 V mains power supply and at least one of its side air openings must be open.

Switching the unit on and off

The **on** and **off** buttons are used to switch the unit on or off respectively.

Setting the blower levels

The unit always starts with the last blower level that was set. The blower level can be changed at any time.

– Press the **+** button once:

blower level increases (blower has a delayed response).

– Press the **-** button once:

blower level decreases

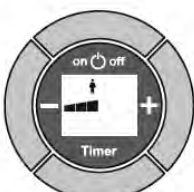
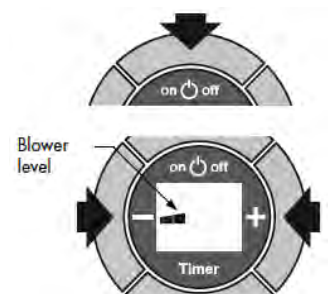
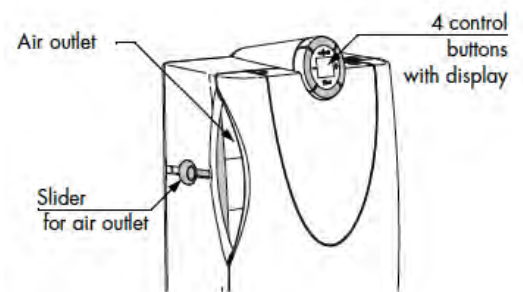

Recommended blower level for when one person is in the room: $30 \text{ m}^3/\text{h}$

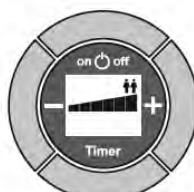

Recommended blower level for when two people are in the room: $60 \text{ m}^3/\text{h}$

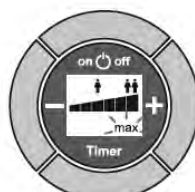

Maximum blower level: $180 \text{ m}^3/\text{h}$
(max indicator flashes)

Timer function

The **Timer** button is used to activate and deactivate the Timer function. When the timer is activated, the timer starts the unit for a preset run time (in hours). This is preset at the factory to 8 hours. The blower automatically switches off after the run time has elapsed. 24 hours after the timer has been activated, the unit restarts automatically with the settings that were last selected. This procedure is repeated cyclically every 24 hours. The function ends when the timer is switched off.

Note: After a power failure, the timer must be activated again.

Setting the timer

The timer run time may be set to a value between 1 and 18 hours and can be changed at any time.

1. Press the **Timer** button once (pressing the button again ends the Timer function).
2. **a.** To shorten the run time, press the **-** button immediately.
2. **b.** To extend the run time, press the **+** button straight away.

The display lights up briefly, the clock symbol flashes, and the set blower level plus the run time in hours are displayed.

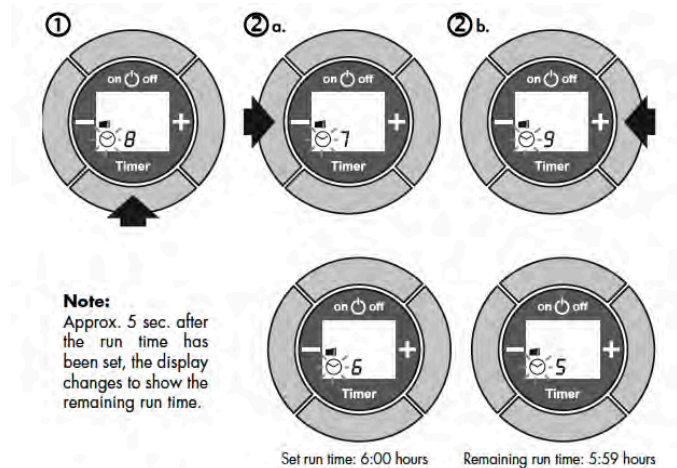

Maintenance: Replacing the Filter

Replacing the filter

The filter must be replaced when the air throughput starts to diminish. The **L** filter change indicator appears on the display after an operation period of six months.

Removing and fitting the filter

1. Switch off the unit. Depress the two markings on the top of the front panel while pulling the panel towards you.
2. Grip the bottom of the filter frame's bar and remove the frame from the fixing.
3. Remove the filter from the frame and insert a new filter.

Note: Insert the F5 filter so that its smooth surface is facing the holding bar.

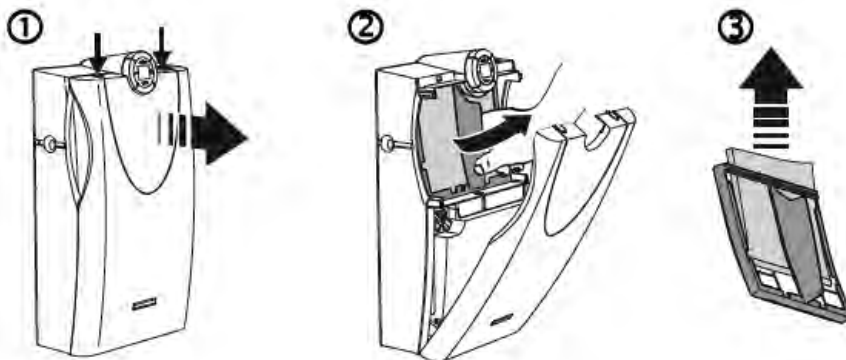

4. Push the filter frame back into the fixing and close the front panel until it locks into place.
5. Press the **-** button for approx. 5 sec. until the **L** filter change indicator disappears.

Cleaning the Air Duct

Removing the protective grid

If there is a build-up of dirt in the unit's air duct, it must be cleaned.

To do this, it is necessary to remove the filter as well as the protective grid.

WARNING Exposed electrical components. Risk of fatal injury from electric shock or fire.

Before opening the unit, always unplug the mains plug from the socket (do not pull on the cable), in order to disconnect the unit from the mains power supply. When a permanent mains connection is used, switch off the power to the unit.

1. Depress the two markings on the top of the front panel while pulling the panel towards you. Pull out the front panel. At the point of resistance, keep on pulling until the panel is released from the fixing. Grip the bottom of the filter frame's bar and remove the frame from the fixing. (see page 20)
2. Insert a suitable slotted screwdriver through the protective grid's central opening into the horizontal slot of the catch on the unit's rear panel, while pressing down the foam on the inside.
3. Push the screwdriver into the catch until the fastening clip is released.
4. Remove the protective grid from the guide.
5. Carefully clean the air duct manually using a vacuum cleaner, for example.

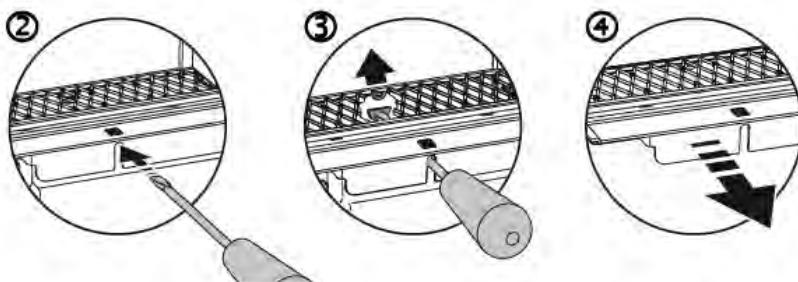
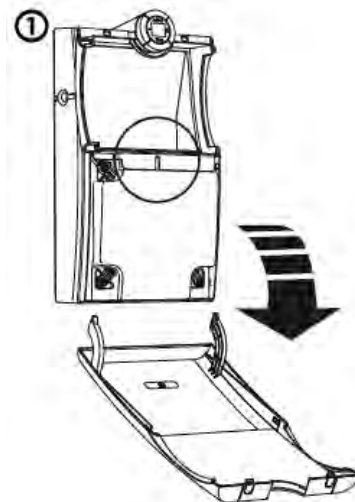

Fitting the protective grid

1. Slide the protective grid into the guiding groove on the right and on the left.
2. Press the protective grid lightly against the rear panel. At the same time, carefully lift the fastening clip and push into the catch.

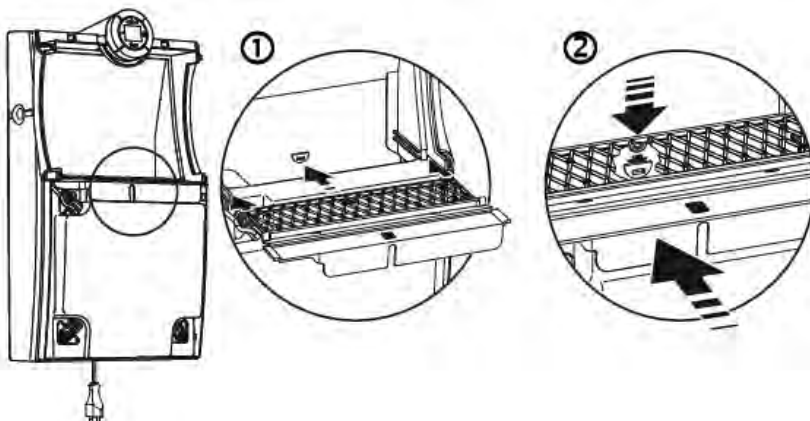

Attaching the front panel

1. Position the lower edge of the front panel horizontally onto the lower edge of the unit.
2. Press the front panel's two holding arms inwards while closing the front panel at the same time. While closing, ensure that the edge of the front panel is resting on the lower edge of the unit.

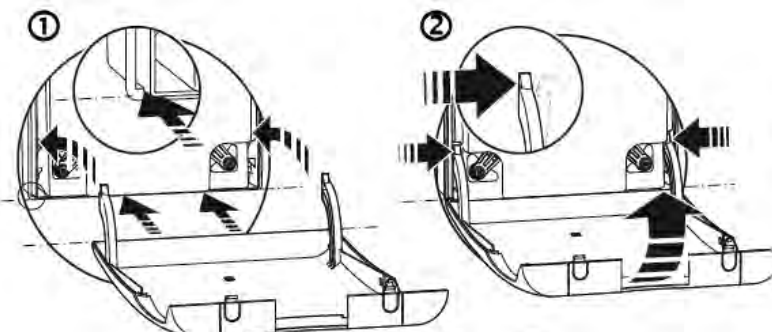

Product Liability

Directions of use

Any inappropriate or unconventional use of the product, or failure to operate correctly will deem the product to be excluded from warranty. Any adjustment or change to the product or its components without prior authorisation by Acoustica is strictly forbidden.

Warranty

A 3 year warranty is given, subject to the correct installation and use of the product, in accordance with the statutory regulations.

As part of any remedial work we are entitled to replace individual components or whole units in the installation.

Consequential harm caused by a defect is excluded from the warranty – insofar as legally permissible.

Should any alterations to the product and / or to the individual components be made that have not been authorised by Acoustica or have not been described here, or should the product and / or individual components be un-assembled or dismantled, the warranty shall be deemed null and void.

Exclusion of liability

The product and its component parts are subject to strict quality control. They will thus work safely and reliably when used normally. We rule out our liability for consequential harm caused by a defect and / or for claims for damages unless we have acted willfully or with gross negligence or respectively are responsible for injury to life, body or health. This does not affect any liability under the product liability law, irrespective of who is to blame. Also unaffected is the liability for the culpable breach of fundamental contractual obligations; the liability in such cases however is limited to the foreseeable damage typical of the contract. There is no change to the burden of proof to the detriment of the consumer associated with the above rulings.



Ground Flr, 6a Nelson St
Annandale NSW 2038
Australia
Tel: +61 2 9550 2900
Fax: +61 2 9550 5665
info@acoustica.com.au
www.acoustica.com.au